

IoT Based Gas Leakage detection System Using GPS

V Praveen Sharma^{1*}, *Dugyala Raman*², *V Padmavathi*³, *G Vijendar Reddy Gurram*⁴

¹Department of Computer Science and Engineering, Chaitanya Bharathi Institute of Technology, Hyderabad-500075

²Department of Computer Science and Engineering, Chaitanya Bharathi Institute of Technology, Hyderabad-500075

³Department of Computer Science and Engineering, Chaitanya Bharathi Institute of Technology, Hyderabad-500075

⁴Department of Information and Technology, Gokaraju Rangaraju Institute of Engineering and Technology, Hyderabad-500090

Abstract. Gas leaks are a significant problem since they may have disastrous effects on infrastructure, human health, and greenhouse gas emissions, among other things. A method for early detection and alerting of gas leaks is required to reduce these dangers. In this project, we suggest a low-cost and efficient cloud-based Internet of Things (IoT) gas leak detection system for usage in residential, commercial, and industrial contexts. An Arduino Uno microcontroller, a Wi-Fi module, and a MQ 2 gas sensor make up the system. The sensor notifies the microcontroller when gas is detected, and the microcontroller analyses the information before sending it to the cloud through the IoT module. The cloud platform offers a user-friendly interface for managing and visualising data on gas leaks, and it also notifies customers through email and SMS. The system comes with a GPS module and a smoke detector for real-time position tracking and fire detection. The smoke detector detects smoke and sounds an alert, while the GPS module monitors the system's location. These qualities enable the system to effectively reduce the dangers of gas leaks and fires while enhancing environmental safety.

Keywords: Arduino Uno , MQ Sensor , ESP Module

1 Introduction

By enabling common things to connect to other systems and devices and share data through sensors, software, and other technologies, the Internet of Things (IoT) has completely changed the way we live. IoT devices are widely employed in a variety of industries, including healthcare, agriculture, traffic monitoring, safety management, and environmental monitoring. These devices range from simple home goods to sophisticated industrial

* Corresponding author: praveensharmavavilala@gmail.com

machinery. IoT, for instance, has the ability to automate farming procedures and tackle issues like an increasing population and unreliable human resources in agriculture. IoT may be quite useful in the chemical sector for maintaining safety procedures and keeping track of the environmental impacts of chemical manufacturing. IoT devices, however, have security issues, therefore developers must make security a major focus. [1]. Chemical catastrophes may have terrible effects, including the loss of life, destruction of property, and pollution of the environment. The greatest chemical catastrophe in history happened in 1984 in Bhopal, India, where the leak of methyl isocyanine gas resulted in the deaths of over 2,500 people. India has nevertheless had chemical catastrophes that have caused deaths, injuries, and environmental harm even after this tragedy. Early gas leak identification and notification can be crucial in reducing mortality from such catastrophes [2]. In this project, we suggest a gas leak detection system that employs a gas sensor to find potentially harmful gases, setting off an alert and notifying the proper person through SMS. However, maintaining the security of IoT devices continues to be a major priority in dealing with such problems.

1.1 Related Work:

Author [3] has presented a smart gas stove with a gas leakage detection and monitoring prevention system. To identify the leak, he employed machine learning algorithms and sensor devices. Authors [4] and [5] have proposed gas leakage detection systems using MQ sensors and communication technology to send the alert message to the user, and authors [6] have proposed implementing a gas leakage detection system using MQ 6 sensors and a solenoid valve to shut off the gas supply. Gas leakage is detected by using gas sensors, and alertness is sent to the people through communication technologies.

1.2 Problem Definition

The problem being addressed is the lack of real-time position tracking and smoke detection capabilities of current gas leak detection systems. This inadequacy highlights the need for an improved system and poses a substantial challenge in terms of emergency response and risk management.

2 Proposed Methodology

Integration of IoT and cloud technologies is a potential future route for the creation of a gas leakage detecting system. By using cloud technology to store sensor data for later use and incorporating a GPS module to accurately pinpoint gas leaks, the suggested system offers a better strategy that outperforms earlier techniques. To find smoke leaks, the system may also have a smoke detection sensor. This system may be realised using parts like a GSM module, Arduino microcontroller, fire sensor, and MQ 2 Gas sensor.

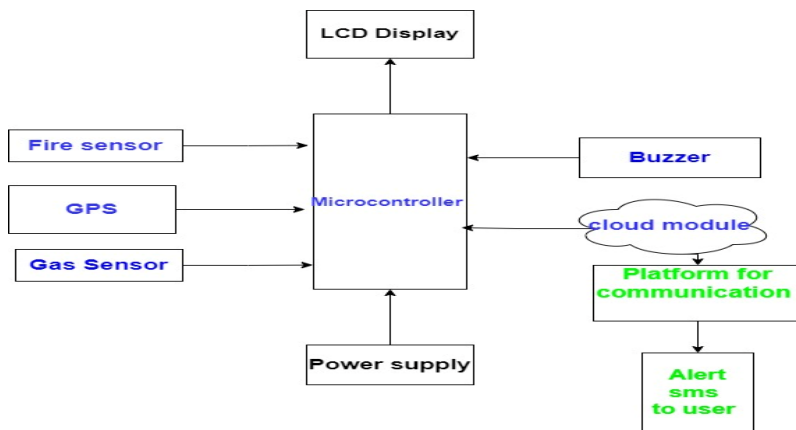

Fig.1. System Architecture

3 Experiment Results

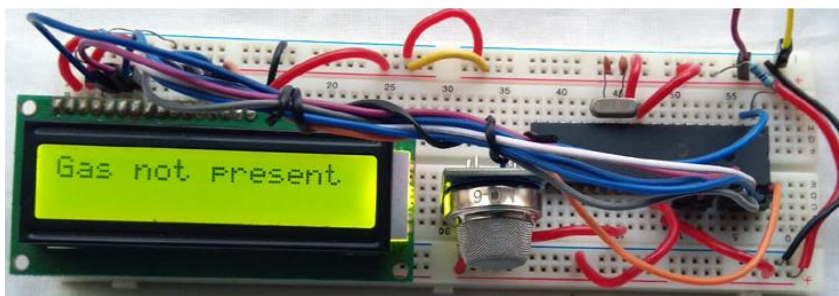

Fig.2. Lcd Displaying that gas has been not identified

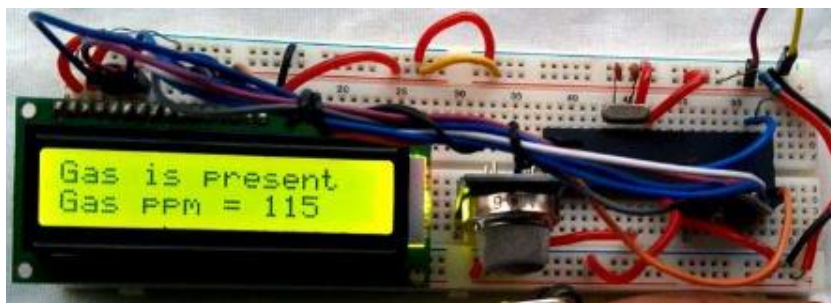

Fig.3. Lcd Display Showing that Gas Leakage has been identified

To operate and process data obtained from the MQ sensors, smoke sensor, and GPS module, the system makes use of the Arduino Uno microcontroller. After processing this data, a cloud platform can offer users warnings and insights. Through a web or mobile application, users of the cloud platform may configure alarms for gas or smoke detection and receive real-time data and warnings. Geographical data and alerts from the cloud platform are provided on the user interface.

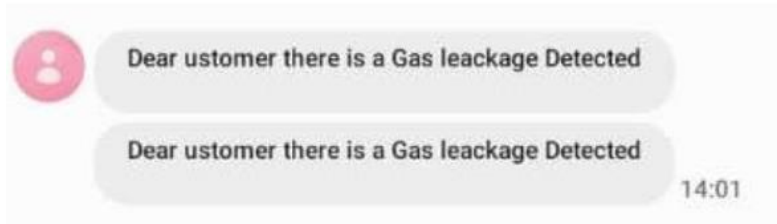

Fig.4. Shows that Alert sms has been sent to users.

4 Conclusion

IoT and cloud technologies are used in the proposed gas leakage detection system to offer a more effective and efficient method of finding gas leaks. The system can identify gas leaks, determine their position, and detect smoke by fusing a GPS module with a smoke sensor. Additional security features like fire sensors are also incorporated in the proposed system, and the sensor data may be saved in the cloud for further analysis and usage. In conclusion, this system offers a complete gas leakage detection solution that can assist avert dangerous situations and save lives. We may anticipate even more important breakthroughs in gas leakage detection systems in the future because to continuous developments in IoT and cloud technology.

References

1. <https://bytebeam.io/blog/top-8-challenges-in-iot-developmentand-how-to-overcome-them-cl5m9r7e1381521olz82atno32>
2. <https://vikaspedia.in/social-welfare/disaster-management-1/man-made-disasters/chemical-disaster>
3. Zhu, Junxiao, et al. "Gas pipeline leakage detection based on PZT sensors." *Smart Materials and Structures* 26.2 (2017): 025022.
4. Stajanca, Pavol, et al. "Detection of leak-induced pipeline vibrations using fiber—Optic distributed acoustic sensing." *Sensors* 18.9 (2018): 2841."
5. Leavline, E. Jebamalar, et al. "LPG gas leakage detection and alert system." *International Journal of Electronics Engineering Research* 9.7 (2017): 1095-1097
6. John, Alan M., et al. "LPG/CNG gas leakage detection system with GSM module." *International Journal of Advanced Research in Computer and Communication Engineering* 6.5 (2017): 536-540